

► Basic Designs Pre-Wired Junction Box Assembly without Meter Base and Cable Connections

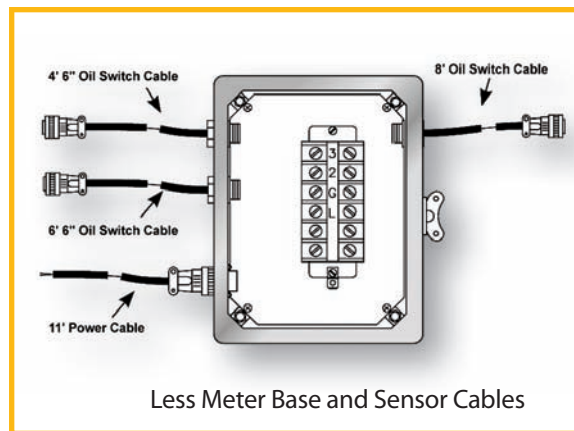

Less Meter Base and Sensor Cables

Part #:
CP-0207-PNC
Junction box assembly includes transformer cable, (3) oil switch connectors and mil-spec connectors.

Features & Options:

- Available in multiple configurations
- Non-Corrosive and waterproof casing
- Available with and without meter base and sensor cables

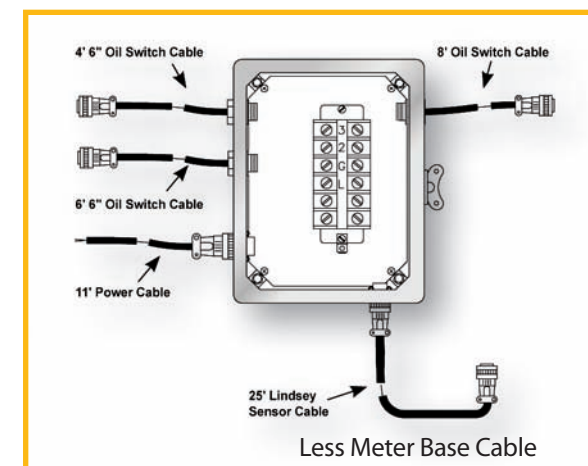

Less Meter Base Cable

Part #:
CP-0208-LS-PNC
Junction box assembly includes transformer cable, Lindsey sensor cable and mil-spec connectors.

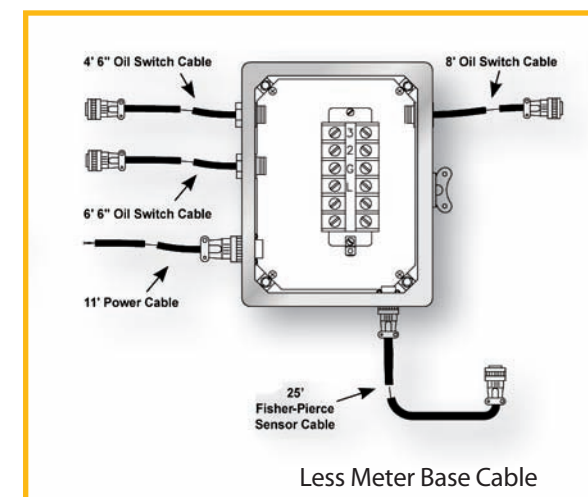

Less Meter Base Cable

Part #:
CP-0208-FP-PNC
Junction box assembly includes transformer cable, Fisher-Pierce sensor cable and mil-spec connectors.



► With Pelco Products, innovation always comes standard.

Pelco Products, Inc. is a centrally located, Oklahoma based, family-owned business specializing in designing, engineering, manufacturing and distributing poles, brackets and associated products utilizing castings, extrusions, forgings and stampings.

With engineering as the catalyst for growth, Pelco Products is proud of its Engineering Team consisting of 29 engineers and technical staff with over 400 combined years of experience.

Founded in 1985 in a 2,500 square foot facility with 5 employees, the company now employs over 265 team members in 315,000 square feet of manufacturing space. The company is dedicated to serving its three primary markets (i.e. utility, traffic and ornamental) globally through Innovative Solutions, Quality Products & Unparalleled Customer Service.

Please contact Pelco Products today for more information by calling 405.340.3434 or email us at sales@pelcoinc.com.

"We sell *service* and it just happens that we manufacture products that allow us to sell our *service!*"

Steve Parduhn
Vice President/ Owner
Pelco Products, Inc.



405.340.3434 • sales@pelcoinc.com
320 West 18th Street • Edmond, OK 73013
www.pelcoinc.com

Scan this code to see all our great utility products.



Junction Box & Wiring Harness for Capacitor Bank Distribution

► **Designed For Use By:**
Investor Owned Utilities
Rural Electric CO-OPS
Municipalities

▶ Pelco's Junction Boxes provide an *economical advantage* over traditional capacitor bank installations.

What typically requires 16-20 man hours of installation time, a bucket truck, two linemen, supervisor and a supervisor's truck can now be completed in two hours, without the need of guesswork. Pelco's Junction Boxes are delivered factory assembled, pre-wired and ready for immediate installation. **Our fail-safe "plug and play" design allows for a simplified, safe and worry-free installation.**

Designed for utility use, all Junction Box assemblies are weather-resistant and have obtained the NEMA-4X rating, providing an extreme level of protection against the ingress of water to the terminal bank, and an additional level of protection against corrosion to the exterior.

Unlike other capacitor junction boxes containing plastic connectors, Pelco's designs are equipped with **durable aluminum non-corrosive Mil-Spec/Amphenol connectors** that are built to last.

Efficiency

- Simplified Installation
- Factory Assembled and Pre-wired
- Fail-Safe Plug and Play Design
- Reduced Labor Costs and Time
- Wiring Schematic Included for Ease of Installation
- Oil/Vacuum 5 Pin Standard
- Control Agnostic

1 Durable, High-Strength Designs

2 Waterproof, Weather-Resistant, Non-Corrosive & Ultra-Violet Protection

Quality Construction

3 Aluminum Multi-Pin Mil-Spec Amphenol Connector comes Keyed, Sized & Wired

6 1 Year Warranty

5 100% Factory Testing and Inspection

4 Custom Configurations Available Upon Request

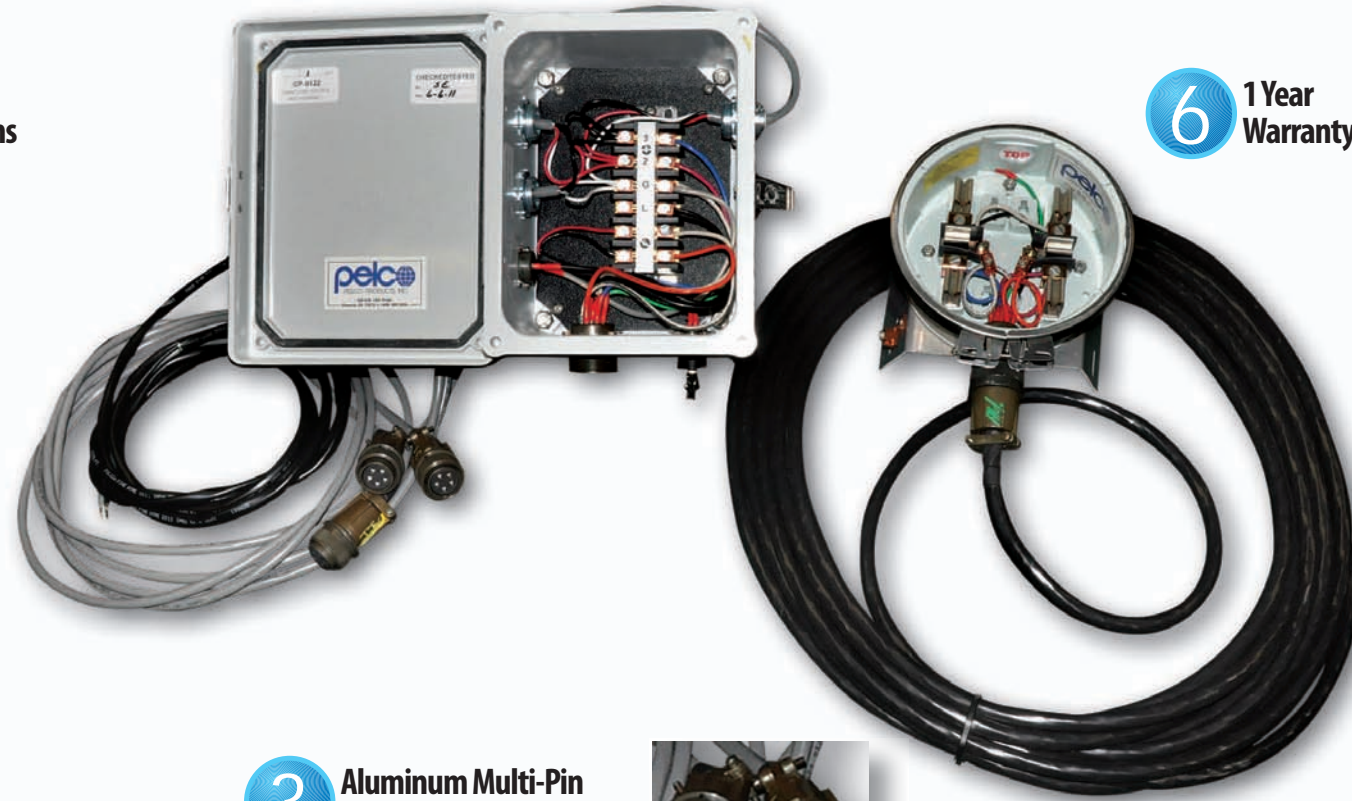

▶ Basic Plus Design

Junction Box Assembly, Pre-Wired with **Time, Temperature, Voltage Control** with **Meter Base** and **(3) Oil Switch Cables**.

Part #: **CP-0202-PNC**
Junction box assembly with **4-Jaw J40 meter base assembly**. Includes transformer cable and mil-spec connectors.

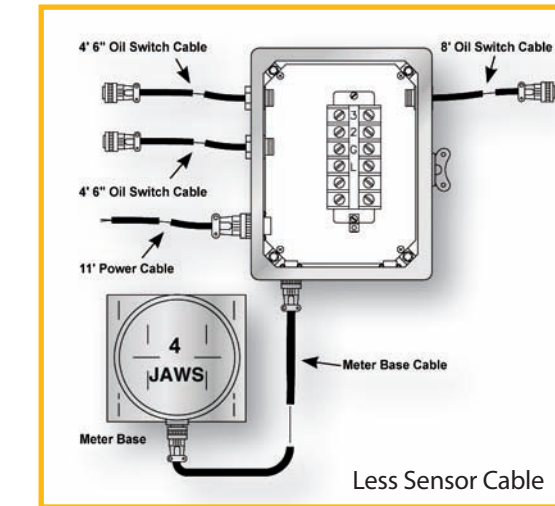

▶ Meter Base Configuration Options

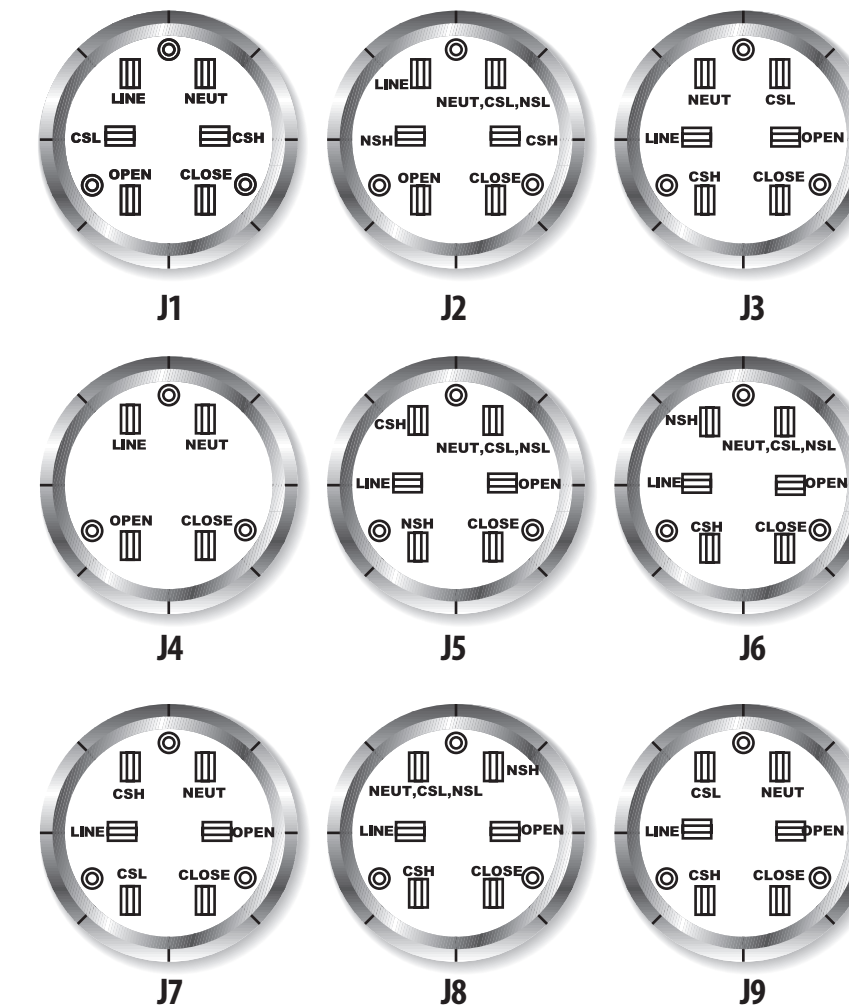

Custom configurations and cable lengths available for all designs.

*Call Pelco for options.
405.340.3434
pelcoinc.com*

Innovation
Quality
Service

▶ Full-Feature Designs

Junction Box Assembly, Pre-Wired with **Volt-Ampere Reactive Power (VAR), Current, Time, Temperature, Voltage Control** with **Sensor Cable, Meter Base Options** and **(3) Oil Switch Cables**.

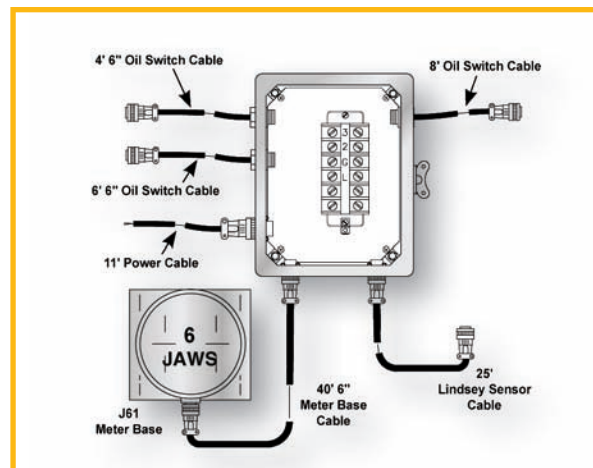

Part #: **CP-0209-LS-J61-PNC**
Junction box assembly with **6-Jaw J61 meter base assembly**. Includes transformer cable, Lindsey sensor cable and mil-spec connectors.

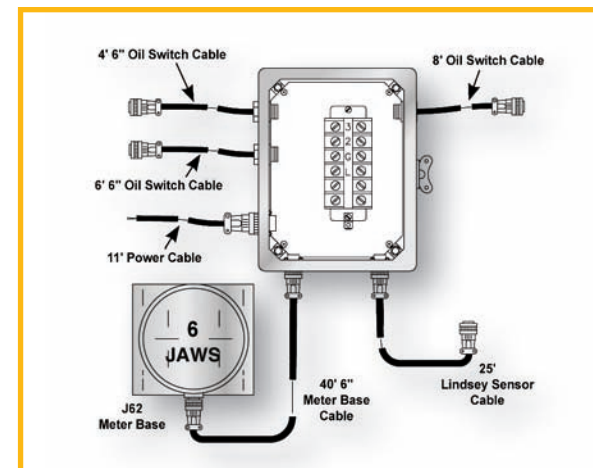

Part #: **CP-0209-LS-J62-PNC**
Junction box assembly with **6-Jaw J62 meter base assembly**. Includes transformer cable, Lindsey sensor cable and mil-spec connectors.

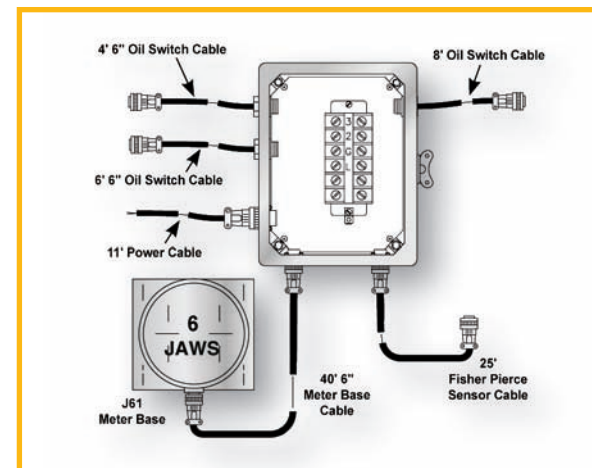

Part #: **CP-0209-FP-J61-PNC**
Junction box assembly with **6-Jaw J61 meter base assembly**. Includes transformer cable, Fisher-Pierce sensor cable and mil-spec connectors.

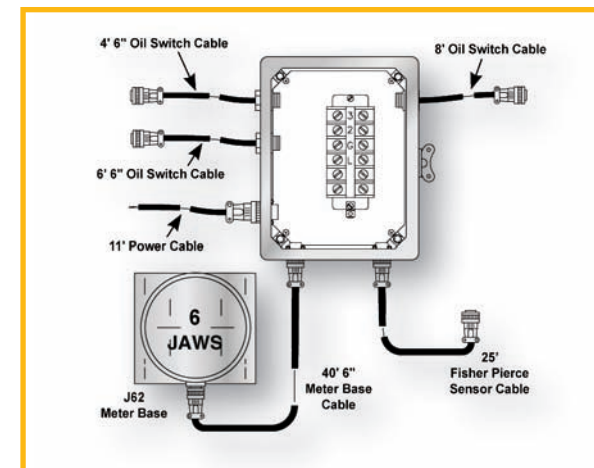

Part #: **CP-0209-FP-J62-PNC**
Junction box assembly with **6-Jaw J62 meter base assembly**. Includes transformer cable, Fisher-Pierce sensor cable and mil-spec connectors.