

INSTALLATION INSTRUCTIONS

ASTRO-BRAC CLAMP ASSY 5/8" Stainless Steel Bands

Tools Required: 1/2" & 11/16" Socket & Ratchet or Box End Wrench (approx. 7" length),
5/32" Allen Wrench, Pliers, Band Cutter, Hack Saw,
Optional: 0-50 ft./lb. Torque Wrench or equivalent

Attaching Clamp Kit to Mast Arm

1. Place Female Clamp Half on mast arm with Clamp Screw Assembly as shown in Figure 1. Orient Clamp Kit so Clamp Screw Assembly will be on top side of arm as shown in Figure 6. Place Clamp Screw Assembly in pawl of Female Clamp as shown in Figure 1 allowing two to three (2-3) threads exposed beyond the nut on the Clamp Screw Assembly. (Figure 2)
2. Bend stainless band around arm and mark on band at the point where band makes contact with the slotted end of the screw assembly. (Figure 3)
3. Slide Band Buckle on band with setscrew to the outside. (Figure 4) Bend band to the inside at point where mark was made in Figure 3 and slide Clamp Screw Assembly on band. (Figure 4)
4. If free end of band is too long to wrap inside of band, cut off extra length. **NOTE: MAKE CERTAIN FREE END IS TURNED TO THE INSIDE AND IS A MINIMUM OF 4" IN LENGTH.** (Figure 4)
5. With a pair of pliers, crimp the bend in the band around the clamp screw and slide Band Buckle on the free end of the band as close to the screw assembly as possible. (Figure 5) Tighten the setscrew in the band buckle snugly (8-10 ft. lb.) with allen wrench.

CAUTION: Make certain measurements are correct **BEFORE** bending band. Once band is bent and crimped, **DO NOT** straighten and rebend. Replace with new band. The bending process stresses the band and repeated bendings may cause fatigue resulting in loss of strength.

6. Back off nut on Clamp Screw Assembly until it is flush with clamp screw end. Insert Clamp Screw Assembly on Clamp Pawl. Rotate Clamp Screw Assembly so it is on the side of the mast arm with the Clamp Screw Assembly at the top. (Figure 6)
7. Tighten nut on Clamp Screw Assembly until it is just snug enough to hold clamp kit in position. **DO NOT TIGHTEN SECURELY UNTIL STEPS 8-10 BELOW ARE COMPLETED.**

Attaching Signal and Tube Assembly to Clamp Kit

8. Position Tube into Male Half of Clamp Kit. (Figure 7) Insert V-bolts as shown and attach with lock washers and nuts.
9. Aim and position signal to the desired height and direction and tighten nuts on two (2) V-bolts to 12-15 ft. lbs. of torque. **DO NOT OVERTIGHTEN.**
10. Plumb or level signal and tighten two (2) 5/16" Bolts on Female Half of Clamp Kit to 20-22 ft.lbs. of torque. **DO NOT OVERTIGHTEN.**
11. Tighten Clamp Screw Nuts (2) to 20-22 ft. lbs., using an 11/16" box end wrench or ratchet. (Figure 7) **NOTE:** Tightening the clamp screw nuts firmly with a 7" wrench will produce approximately 20 ft. lbs. of torque. This is all that is necessary to hold the Astro-Brac Clamp Kit in place. **DO NOT OVERTIGHTEN.**

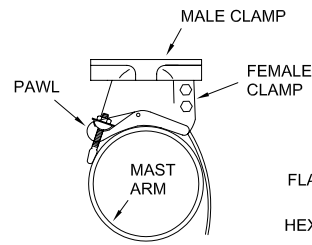

Figure 1

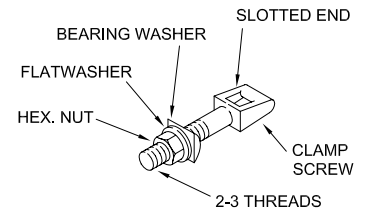

Figure 2

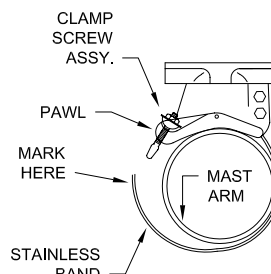

Figure 3

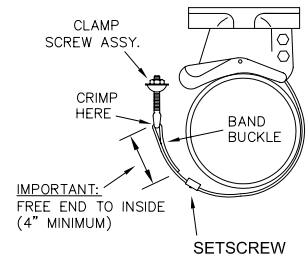

Figure 4

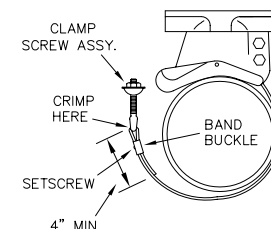

Figure 5

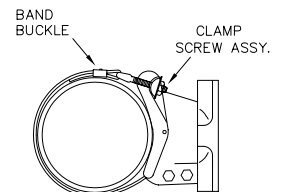

Figure 6

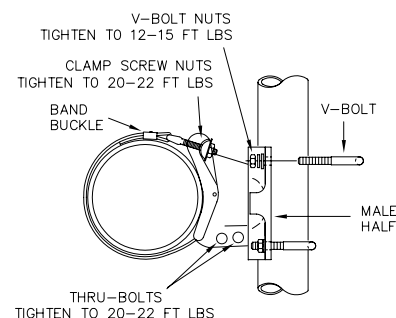

Figure 7

INSTALLATION INSTRUCTIONS

ASTRO-BRAC CLAMP ASSY

5/8" Stainless Steel Bands

For All Arm and Tube Kits:

Gusseted  and Solid 

1. Mount lower arm to bottom of signal. Position arm so that tube boss will be centered in back of signal. (Figure 1). Using hardware kit without rubber gasket, secure arm to signal.
2. Screw tube into lower arm, being sure to stop at a point where the channel (if using a gusseted tube) is at the back, facing directly away from the signal. Slide upper arm down over top of tube and secure to signal, using hardware kit with rubber gasket. Hardware kit should be installed against the inside top of signal. (Figure 2).
3. After upper and lower arms are secure, and tube channel (if gusseted tube) is centered at back of tube, tighten setscrews in upper and lower arms. This will prevent rotation of tube after installation. (Figure 3).
4. Using hack saw, cut off any excess tube which may protrude above the upper arm. (Figure 4).
5. Finished assembly is now ready for installation on Clamp Kit. (Figure 5).

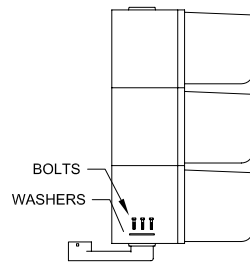

Figure 1

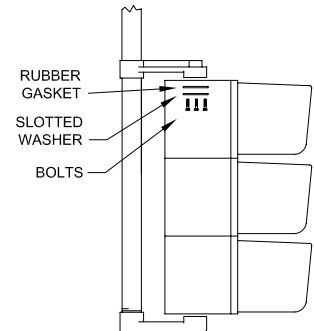

Figure 2

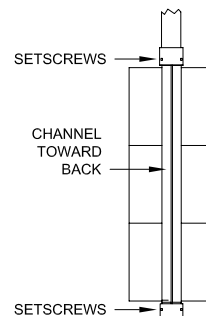

Figure 3

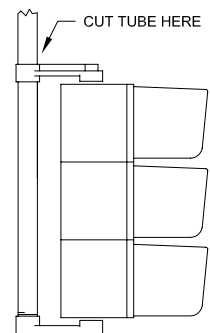

Figure 4

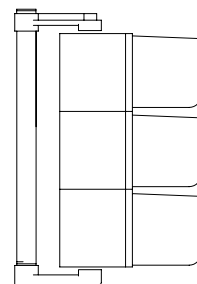
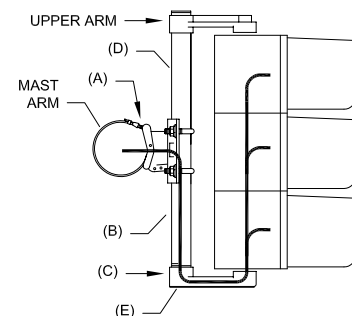

Figure 5

COVERED BY ONE OR MORE OF THE FOLLOWING U.S. PATENTS:
3586280, 3764099, 3854685, 4659046. OTHERS PENDING.

How To Wire When Using The Astro-Brac:

1. Wiring from inside the mast arm should be fed through field drilled hole in the mast arm and brought through Clamp Kit (A) to extruded Aluminum Support Tube (B) to Lower Arm (C) and to signal connections.
2. After running wire, cut Vinyl Insert to length and insert in Gusseted Tube (D).
3. Slide in Bottom Cover (E) and snap into place.



No Other Adjustable Bracket Gives You...
COMPLETELY CONCEALED WIRING!

The Astro-Brac provides the most versatile mounting system available